

# **IR** INFRARED INDUSTRIES



## **IR-8400D**

**Continuous Gas Monitoring Analyzer**



# Operator's Manual

© **Infrared Industries**  
25590 Seaboard Lane  
Hayward, CA 94545  
Phone 800.344.0321 • Fax 510.782.8101  
[www.infraredindustries.com](http://www.infraredindustries.com)



# Table of Contents

---

UNPACKING AND VISUAL INSPECTION .....	6
<b>UNPACKING INSTRUCTIONS</b> .....	6
<b>REPORTING DAMAGE</b> .....	6
INTRODUCTION .....	8
SPECIFICATIONS.....	10
TOOLS, EQUIPMENT, AND SUPPLIES .....	12
<b>Tools</b> .....	12
<b>Electronic Test Equipment</b> .....	12
<b>Zero And Calibration Gases</b> .....	12
<b>Gas Handling Equipment</b> .....	12
INSTALLATION .....	14
<b>GENERAL</b> .....	14
<b>PRECAUTIONS</b> .....	14
<b>MECHANICAL</b> .....	14
<b>ELECTRICAL</b> .....	16
<b>GAS CONNECTIONS</b> .....	17
CONFIGURING THE ANALYZER .....	18
<b>STANDBY</b> .....	18
<b>IDENTIFYING ACTIONS WHEN PUMP IS On</b> .....	19
<b>Menu 1</b> .....	20
<b>MENU 2</b> .....	21
CALIBRATION AND OPERATION.....	22
<b>GENERAL OPERATION</b> .....	22
<b>MEASURING GASES</b> .....	22
<b>CALIBRATION</b> .....	22
<b>RECOMMENDED CALIBRATION SCHEDULE</b> .....	23
<b>Auto Calibration</b> .....	23
IR SAMPLE CONDITIONER .....	28
<b>IR1150/1151 SAMPLE CONDITIONER</b> .....	28
<b>INSTALLATION</b> .....	30
<b>INITIAL SETUP</b> .....	30
<b>OPERATION</b> .....	30
<b>FILTER REPLACEMENT</b> .....	30
WARRANTY.....	32
<b>Warranty for Analyzers and Accessories</b> .....	32
<b>WARRANTY EXCLUSIONS</b> .....	32
<b>LIMITATION OF DAMAGES</b> .....	32
SERVICE.....	34
INSTRUMENT IDENTIFICATION SHEET .....	36



# *Unpacking and Visual Inspection*

---

## **UNPACKING INSTRUCTIONS**

Open the shipping container and carefully remove the analyzer from the container and packing materials. Inspect the instrument for any signs of damage, such as a broken window or bent conduit. Unscrew the explosion-proof window and remove it from the enclosure. Remove the display board from its supporting brackets and lay it down outside of the enclosure.

Inspect the inside of the analyzer. Check all electrical connections, such as ribbon cables and connectors for proper mating to the PC Boards. Check the gas sample lines from the bulkhead fittings to the optical bench for integrity. If all internal components look proper, replace the display board and screw the front window securely in place.

Remove the junction box cover. Inspect the fuse and terminal board. The cover can be left off for installation purposes.

## **REPORTING DAMAGE**

Should there be any apparent damage to the instrument inside or out, which has occurred due to shipping and handling, notify both the shipper and Infrared Industries immediately. If there is any visual damage to the shipping container or packing material these items should be saved for inspection by the shipper.



# Introduction

The gas analyzer operates by comparing the infrared transmission of two spectral bands through one optical path. One spectral band is centered in one of the absorption bands of the gas being measured. The other spectral band is of a reference wavelength in which there is no absorption by any of the gases present in the sample stream. The difference in the transmittance of these two signals through the optical path is a measure of the optical absorption of the gas being measured in the sample stream as sensed by the infrared detector. The signal from the detector is electronically processed and used to derive a direct measurement of the measured gas concentration in the sample gas.

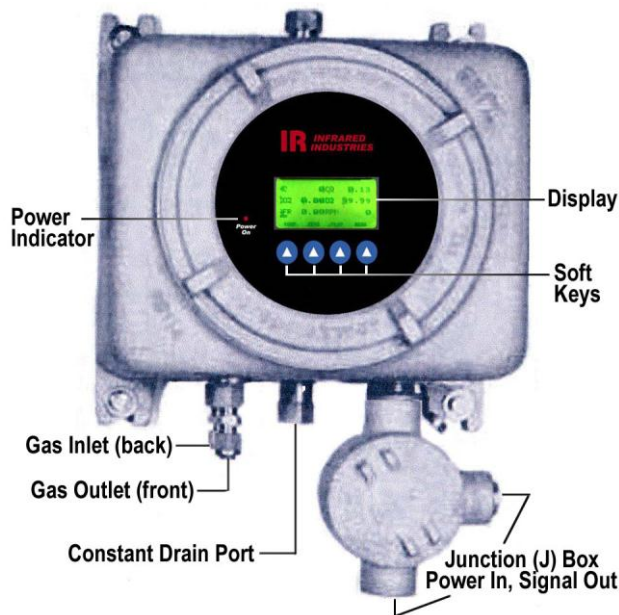

**Figure 1:** IR8400D

The Infrared Industries 8400D series models are non-dispersive infrared (NDIR) gas analyzers, capable of continuously monitoring various gases in a sample stream for extended periods of time. The IR-8400D is designed specifically for the measurement of Hydrocarbons, Carbon Dioxide, Carbon Monoxide, Oxygen, and Oxides of Nitrogen. Other non-standard gases are possible. Contact your IRI representative for further details. The ranges for the IR-8400D are specified by the end users requirements. The instrument is designed specifically for enhanced oil recovery applications as well as refineries and petroleum transfer station. The analyzers are temperature and pressure compensated to achieve

excellent long-term stability and negate the need for frequent calibrations. Built to withstand hostile temperature and weather environments, the analyzers provide as standard, an LCD display, digital RS232 output, analog output, and an isolated linear 4-20 mA current output.

Features include a solid-state detector, a direct-reading display, a low-energy infrared source, a sample cell that is easy to remove and clean, and many field-serviceable components.

# Specifications

---

<b>Measured gases (optional):</b>	HC, CO, CO <sub>2</sub> , O <sub>2</sub> , NO <sub>x</sub> , Butane, Methane, Propane (See identification sheet for specified gas configuration)
<b>Measurement range:</b>	See Identification Sheet
<b>Accuracy:</b>	± 2% of reading or ± 0.5% F.S.
<b>Repeatability:</b>	± 1% of reading or ± 0.5% F.S.
<b>Stability:</b>	24 Hour Period <ul style="list-style-type: none"><li>▪ ± 0.5% F.S. zero drift (Maximum)</li><li>▪ ± 1% F.S. span drift (Maximum)</li></ul> 90 Day Period <ul style="list-style-type: none"><li>▪ ± 1% F.S. zero drift (typical)</li><li>▪ ± 2% F.S. span drift (typical)</li></ul>
<b>Suggested calibration:</b>	6 - 12 Month Intervals
<b>Display (0.7" high-visibility LCD):</b>	Range: 0-110% of full scale standard
<b>Accuracy:</b>	± 1 least significant digit
<b>Output range (linear):</b>	0-100 mV standard. 0-1V, 0-5 V, or 0-10 Vdc optional. 4-20 mA (isolated) RS232 Bi-directional Digital Communication
<b>Fault indication:</b>	Zero signal fault indications standard
<b>Output noise (RMS):</b>	Less than 0.5% F.S.
<b>Output response time (0 - 90%):</b>	Less than 10 seconds (electronic).
<b>Power required:</b>	Standard: 100-240 VAC maximum, 117 Vrms ± 10%, 50-60 Hz, Maximum draw – 2.5 Amps (Optional: 12 VDC / 24 VDC)
<b>Warm-up time for specified performances:</b>	Less than 1 hour.
<b>Sample flow rate:</b>	1 scfh (1/2 sipm) recommended; 2 scfh (1 sipm) maximum, exhaust to ambient
<b>Environmental temperature range:</b>	-40° to 122°F (-40° to 50°C)
<b>Materials of construction (wetted):</b>	316 Stainless Steel, Sapphire, Teflon, Viton, and Polypropylene (typical)
<b>Enclosure:</b>	10.25 x 10.25 x 8.5 inch enclosure with display window and attached 3.50 dia. x 2.50 inch junction box.(See Figure 1)
<b>Enclosure Rating:</b>	NEMA 4 / NEMA 7 (Group C, D, E, Div 1, 2)
<b>Gas Connections:</b>	1/4" compression fitting, sample inlet; 3/8" or 1/4" compression fitting, sample outlet.
<b>Weight:</b>	28 lbs (12.7 kg)

The specifications as stated above are based on a sample stream that is free of particulates and condensable vapors, and regulated to a flow of 1 scfh (1/2 liter per minute).



# *Tools, Equipment, and Supplies*

---

The procedure for calibration and field service of the gas analyzer require the following tools, test equipment, and expendable supplies:

## **TOOLS**

- Screwdrivers, standard (medium and small); and Phillips (medium and small).
- Adjustable wrench.
- Low-power soldering iron.

## **ELECTRONIC TEST EQUIPMENT**

- Oscilloscope, Tektronix Model 912B or equivalent.
- Digital Voltmeter, Fluke Model 8000A or equivalent.

## **ZERO AND CALIBRATION GASES**

- Nitrogen in a pressurized cylinder (zero gas).
- Calibration gas, near full-scale concentration, with a nitrogen balance, in a pressurized, certified cylinder.

## **GAS HANDLING EQUIPMENT**

- Pressure regulators for zero and span gas cylinders.
- Teflon TM\* gas tubing or equivalent, 1/4 inch OD, 10 feet.
- An IR-1151 sampling conditioner or equivalent.

\*Teflon TM is a trademark of E. I. DuPont



# *Installation*

---

## **GENERAL**

The size of the analyzer allows for ease of installation and service. The analyzer was built to be robust and to handle rugged environmental conditions. The instructions below are for a typical installation. If you have any doubts or questions regarding a particular installation, consult our applications engineer at the factory at (800) 344-0321.

**CAUTION: APPROPRIATE SAFETY PRECAUTIONS SHOULD BE OBSERVED WHEN INSTALLING IN A POTENTIALLY HAZARDOUS AREA.**

## **PRECAUTIONS**

To insure accurate operation of the instrument, the following precautions must be taken. The instrument should be shaded from mid-day sun conditions. Direct radiant sun energy on a hot day can cause overheating. Internal temperatures over 140°F (60°C) must be avoided. A sunshade, as discussed later, should be utilized.

Line voltage surge protectors are provided. Infrared Industries may include additional protection devices at the time of installation, if deemed necessary.

## **MECHANICAL**

This analyzer is designed to be mounted vertically on a wall or panel (see Figure 2: IR-8400D Series Outline Dimensions).

You must provide room for access to the instrument on both the bottom and right-hand side (as viewed from facing the front panel). This allows for connections to the gas sample inlet and outlet, and to the electrical junction box on the bottom.

A sunshade is required to protect the instrument from excessive radiant heating. Requirements for the sunshade will vary with geographical location. The primary consideration is shielding from the warmest or mid-day sun. Internal analyzer temperatures must not exceed 140°F (60°C).

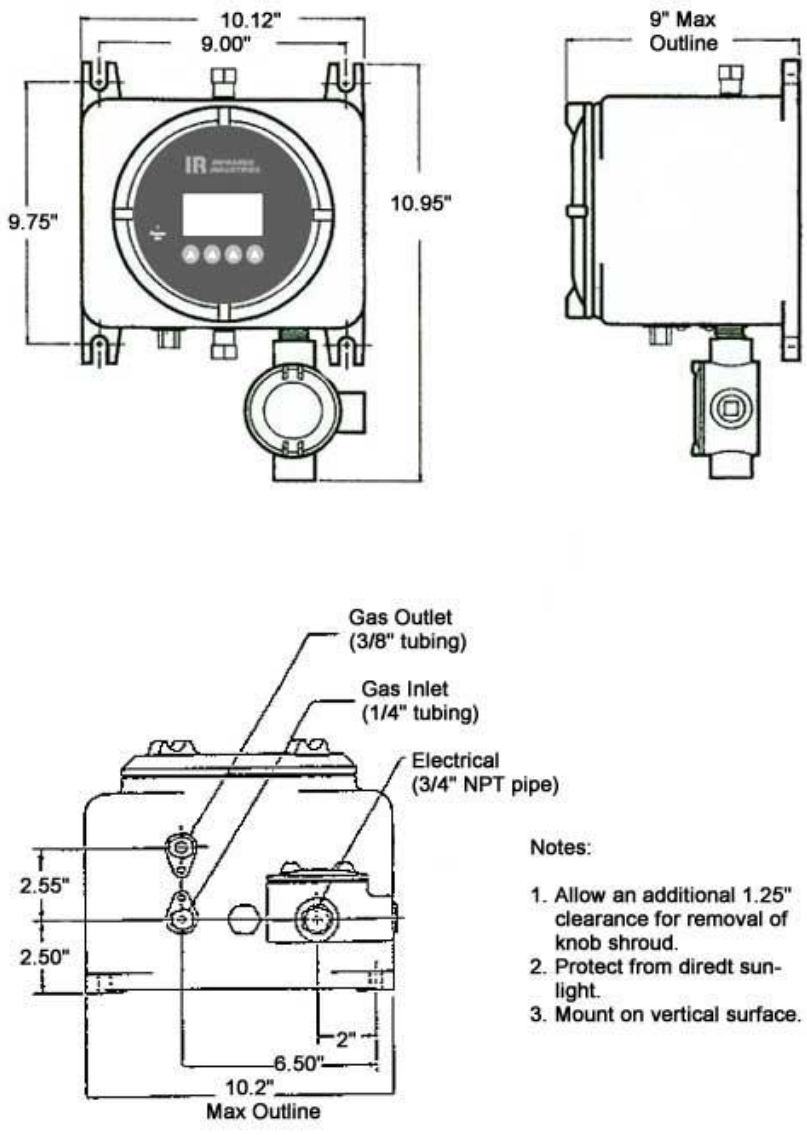
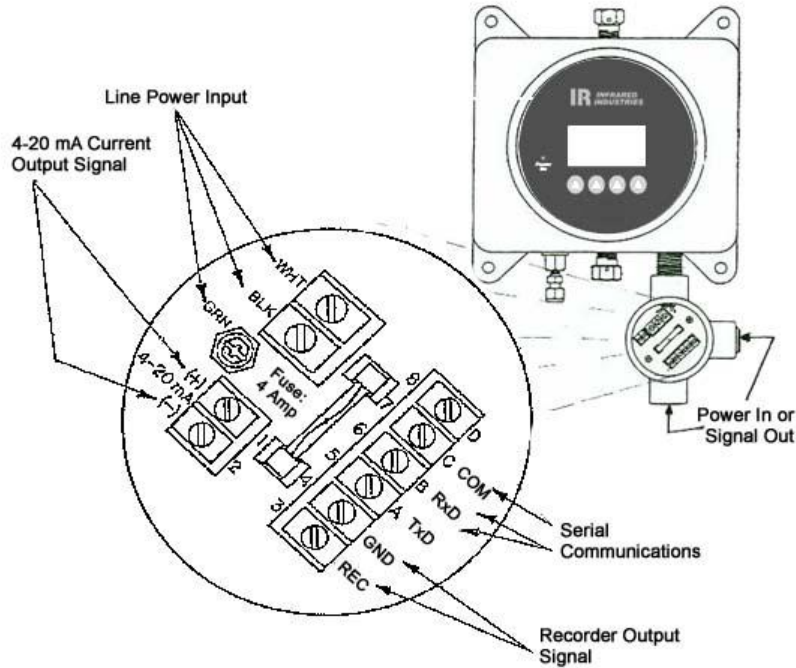

**Figure 2: IR-8400D Outlying Dimensions**

## ELECTRICAL

All electrical interconnections are brought out to a convenient junction box for easy installation. The junction box has a cover, which is easily unscrewed for access to the internal terminals. Two conduits are provided: one for the AC power and the second for the output signals (see Figure 3 for details).

**CAUTION: ALL ELECTRICAL WIRING SHOULD COMPLY WITH THE NEC AND ANY LOCAL STANDARDS.**



*Figure 3: Junction Box Wiring*

A switch or circuit breaker marked as the disconnecting device must be included in the building installation. This device should be in close proximity to the equipment and within easy reach of the operator.

A single-phase power source is required to operate the instrument. The standard instrument requires 100 to 240 volts AC. The hot, neutral, and ground leads should be connected to the appropriate line power inputs using the insulated terminals provided with the instrument (p/n 11002-001). The junction box contains a 2 Amp fuse for the AC power. Replacement parts for the fuses are available from Infrared Industries, Inc. (p/n 11428-001). The outputs available from the junction box include the standard 4-20 mA isolated output and serial communication.

This output can accommodate up to a 600 Ohm loop. Also available is a 0-100 mV dc output. Several optional ranges, such as 0-1, 0-5, or 0-10 Vdc, are available. This output appears at the recorder plus and minus terminals. This signal should feed an input impedance of 1 mega-ohm or greater to prevent loading of the signal. A fault indicator circuit is used to monitor the analyzer. In the event of an instrument failure, this will result in a zero signal output condition, where the display and output signals out will go to zero, indicating an instrument fault.

As an option, the analyzer can be outfitted at any time (field modification) with set point alarms. These contain relay closure outputs with a maximum rating of 10 watts at 28 volts DC.

## **G A S   C O N N E C T I O N S**

Unless calibrated specifically for other pressures, the analyzer requires a feed of clean and dry sample gas at atmospheric pressure for analysis. The sample flow rate should not exceed 2 SCFH (1 SIMP). Since the analyzer is usually calibrated with the sample cell at atmospheric pressure, pressurized gases must be reduced ahead of the analyzer. A typical gas handling system would include a pressure regulator, a coalescing particulate filter, a multiple inlet valve for introduction of calibration gases, and a flow meter with metering valve. A prepackaged sample system, such as the Infrared Industries IR-1150 series, may be provided. The conditioner and analyzer are usually mounted on the same plate.

The inlet gas connection on the analyzer is a 1/4" compression fitting. The standard outlet gas connection is 3/8" compression. It is recommended that the outlet be vented away from the instrument to ambient air. The tubing length and number of bends should be minimized in the vent line to reduce the backpressure in the analyzer sample cell.

**CAUTION: VENTED GAS MAY BE HAZARDOUS (EXPLOSIVE) AND SHOULD BE TREATED ACCORDINGLY.**

# Configuring the Analyzer

After plugging in the 8400D the Power Indicator will be illuminated confirming that there is power to the analyzer - the power supply is properly attached or the unit's battery is charged. Press the On/Off button to activate the analyzer. During the initial power-up, the pump will come on briefly and there will be a status bar at the bottom of the screen to indicate the calibration of O<sub>2</sub>. When this is complete, the Standby Screen will appear. The operator **MUST** zero the analyzer using the corresponding soft key before exhaust gas testing. Refer to Chapter 3 "Display Features" if you are not sure which button to use.

## STANDBY

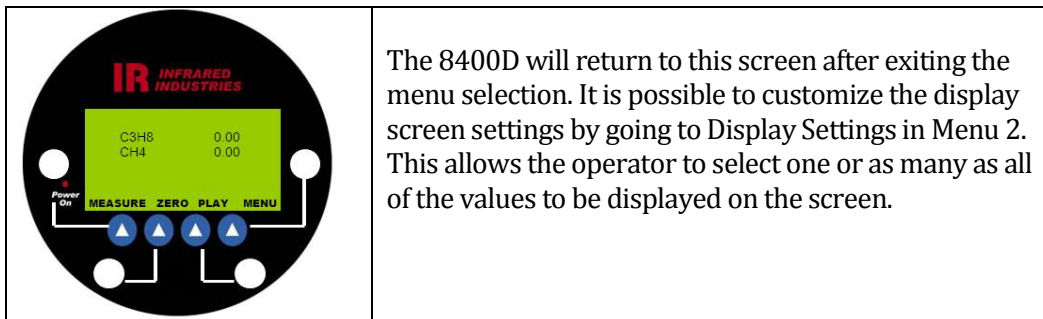

**MEASURE** – Allows manual on/off operation of the pump. This function can also be used to purge gas from the analyzer. For more detailed information, please refer to the section "Identifying Actions When Pump Is On".

**ZERO** – Zeros the analyzer for approximately 1 minute. The pump is automatically controlled during this phase.

**PLAY** – Plays back recorded data. Choose Pause/Continue to control the play function or Exit to return to the Standby screen.

**MENU** – Use this button to access Menu 1

## IDENTIFYING ACTIONS WHEN PUMP IS ON

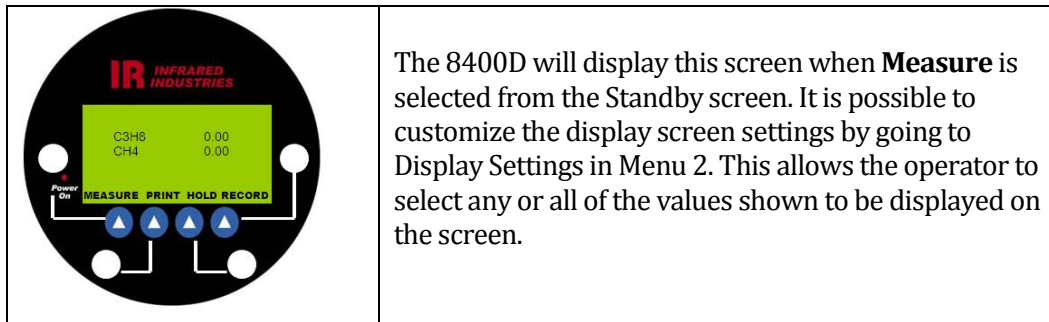

The 8400D will display this screen when **Measure** is selected from the Standby screen. It is possible to customize the display screen settings by going to Display Settings in Menu 2. This allows the operator to select any or all of the values shown to be displayed on the screen.

**MEASURE** – Selecting **MEASURE** allows the operator to turn the pump on and off. When the pump is off, the display will return to the Standby screen. To start pump when the measurement of a specific gas concentration is desired simply press the **MEASURE** button. Once the pump has been turned on the screen menu will change from **MEASURE, ZERO, PLAY, and MENU**, to **MEASURE, PRINT, HOLD, and RECORD**. Pressing the **MEASURE** key once more while the pump is running will stop the pump and return you to the standby menu.

**PRINT** – Prints data to a printer connected to the serial port located in the Junction Box.

**HOLD / RESUME** – Selecting the **HOLD** key will lock the display values to capture that moment in time. Once the **HOLD** key has been initiated the **HOLD** enunciator will change from **HOLD** to **RESUME**. To return to normal operation press the **RESUME** key and return to a live display.

**RECORD** – The analyzer has the ability to store data by selecting **RECORD**. The recorded information will remain in memory until it's erased. To erase the data in memory enter into the Menu 1 options and select Erase Data. Once you have selected this option you will be asked if you wish to erase stored data. Select **YES** to erase data or **NO** and return to the standby screen.

## MENU 1

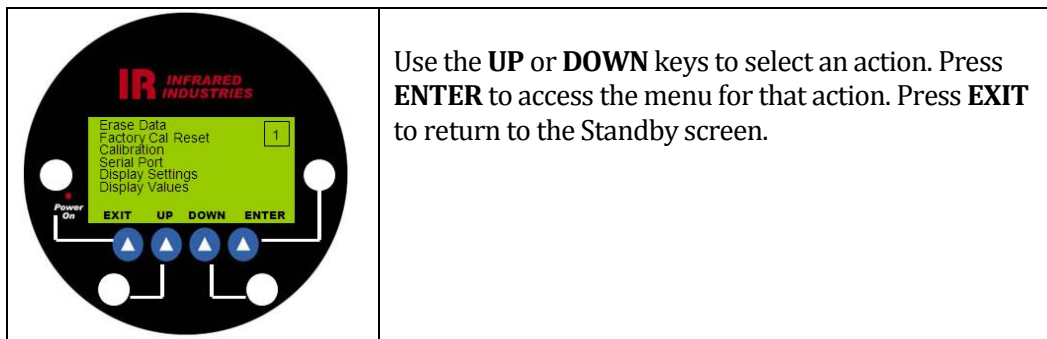

**ERASE DATA** – Select this option to erase data. Select either **Yes** or **No** to erase data and return to the Standby screen.

**FACTORY CAL RESET** – Select **Yes** to reset the factory calibration settings and automatically return to the Standby screen or **No** to go directly back to Standby.

**CALIBRATION** – Once Calibration menu option has been selected, the analyzer will purge itself, perform a zero, and then proceed to the next step. When zeroing is complete, you will be prompted to Enter Tag Values. The tag values should be entered just as they are on the calibration bottle. You are not required to calculate the PEF value for HC. Instead enter the propane value and the analyzer will internally convert it to a hexane HC value. When entering tag values for CO and CO<sub>2</sub> are entered are percentages. For HC and NO<sub>x</sub>, values are entered as ppm. Any gas you do not wish to change the calibration on should be set to --- which indicates no value change. O<sub>2</sub> is self calibrating on atmospheric O<sub>2</sub> (air). To enter the tag values of your calibration gas, use the GAS key to select the gas. Press + to change the value of the highlighted numeral and select the **NEXT** key to advance to the following numeral. When finished, press Continue to advance to the next sequence serene. The screen will prompt you to Turn Cal Gas On and all the values will be shown below. Once the cal gas has been turned on, wait for the values to rise and stabilize then press Continue. This is when the analyzer performs its actual calibration. Do not disturb the analyzer during this period or the accuracy of your calibration could be jeopardized. When calibration is complete, you will be prompted to Turn Calibration Gas Off. When this is completed, press **DONE**, the analyzer will turn on its pump, purge itself, perform an automated zero, and return to the Standby screen. The analyzer is now ready to resume service.

**SERIAL PORT** – This option defines what is connected to the serial port. The two choices are **PC** (to connect to a PC or PDA) or **PRINTER** to connect to an external printer.

## MENU 2

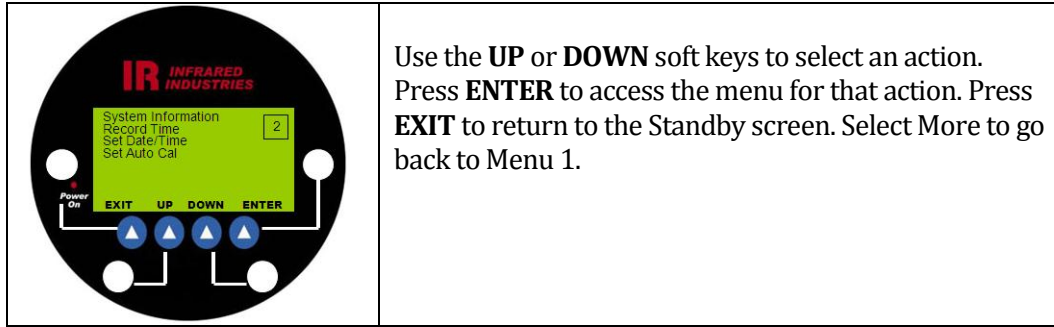

**DISPLAY SETTINGS** – Allows the operator to set degree of Backlight and Contrast. Select the Light key to change the amount of backlight, the Up key for more contrast, and the Down key for less contrast. Select **EXIT** to return to the Standby screen.

**CUSTOMIZE DISPLAY** – Allows the operator to customize the display on the Standby screen. Use the **ENTER** key to select the desired position and the + key to scroll to the desired value using --- to indicate no value to be displayed.

**SYSTEM INFORMATION** – This screen contains information about your system: PEF (propane equivalency factor), the serial number and software version. Press **DONE** to return to the Standby screen.

**RECORD TIME** – Allows the operator to select a specific recording period or to choose manual start/stop. To enter the amount of time you wish to record, use the **NEXT** key to select the desired position and the + key to scroll to the desired value. If manual operation is desired, specify the value as 0.00. After the time is set, select **EXIT** to return to the Standby screen. Once the **PUMP** is turned on, **RECORD** will appear in the lower right corner. Press **RECORD** when you wish to begin recording. The recording period will end automatically once the selected time has expired. If you have set the time for manual control, press **RECORD** when you want to stop recording

# *Calibration and Operation*

---

## **GENERAL OPERATION**

In addition to the Power Indicator, there are four soft keys on the IR-8400D Gas Analyzer. These keys allow you to select actions and change the display accordingly. Each key corresponds to a select position on the screen. When you change screens, the key designators will change to indicate the function of that key.

## **MEASURING GASES**

You can begin measuring gas concentrations once sample supply line has been connected to the ¼ inch Sample Inlet Fitting located on the analyzer. By rotating the gas selector valve located on your sampling conditioner you can select your sample gas, cal gas, and zero gas, to flow to your analyzer. Once you have selected your desired gas then allow a few seconds for the gases to reach the analyzer. While the **MEASURE/PUMP** is on, you can hold or freeze the display values by pressing the corresponding Soft Key.

## **CALIBRATION**

The calibration of the analyzer is straightforward and easily accomplished. It does require a cylinder of compressed nitrogen for zeroing the instrument. Clean, dry air may be used as an alternative to nitrogen. Spanning of the instrument requires a cylinder of certified compressed calibration gas with a nitrogen balance. It is highly recommended that a range of calibration gas near the full-scale value of the instrument be utilized. For example, if the instrument is rated for a 0-50% measurement, the calibration gas range for spanning the instrument should be between 40 and 50%.

After sufficient warm-up, turn the gas selector to **ZERO** on the conditioning unit and allow the zero gas to flow through the analyzer for 1 minute prior to entering the calibration process. To initiate the calibration process, press the **MENU** key. Once you have entered the **MENU** field, press the **DOWN** key until **CALIBRATION** is highlighted. Select this field by pressing **ENTER** once this field is highlighted. When calibration is selected, the instrument will zero itself. Make sure the gas selector on the conditioning unit is still set to zero and zero gas is running through the instrument at this time.

Once the analyzer has zeroed, the display will prompt you to **ENTER TAG VALUES**. The tag values are the concentration listed on your calibration gas bottles. Enter the values using the corresponding soft keys. The **GAS** key selects the desired gas to be set. This is only used if the analyzer is configured to measure more than one gas. The **NEXT** key moves the highlighted cursor from right to left allowing you to select the digit or numeral to be adjusted. The + key will allow you to scroll through the selected numerical

value until the desired numeral is reached. When all the tag values are correctly set, press **CONTINUE** and you will be prompted to **TURN ON THE CALIBRATION GAS**. At this time turn your selector switch on the sampling unit from **ZERO** to **CAL GAS**. Watching the display on the analyzer, you will see the gas values rise as the calibration gas enters the analyzer.

When the values have stabilized press **CONTINUE**. The word **CALIBRATING** and the will appear at the top of the screen and the analyzer will perform the calibration. When complete, you will be prompted to turn off the calibration gas. Rotate the gas selector from **CAL GAS** to **ZERO GAS** and then press **DONE**. Once this is completed, the analyzer will perform a final zero and then come back into **STANBY** mode or **CONDITION**. At this time you may turn off the **ZERO GAS** and put the analyzer back on line by selecting **SAMPLE GAS** on your gas selector.

## RECOMMENDED CALIBRATION SCHEDULE

Calibration schedules are typically set forth by the state compliance standard for the jurisdiction of the monitoring site or by federal standards for your industry. For those areas without federal or state requirements IRI recommends a periodic calibration schedule of every 90 days or upon initiation of any disruption of service.

## AUTO CALIBRATION

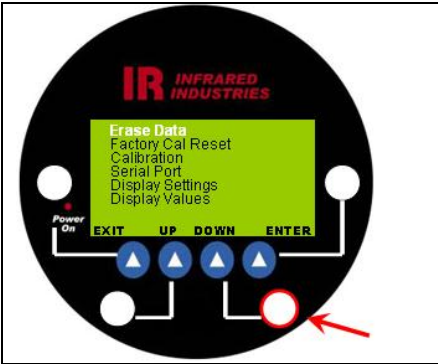
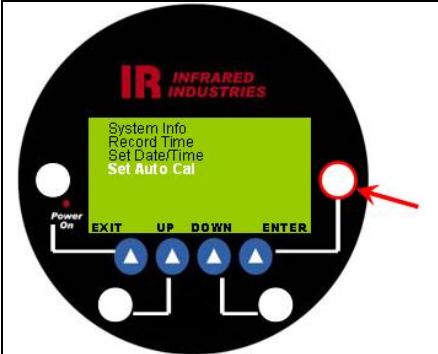
	<p>Select the menu and press <b>DOWN</b> until "Set Auto Cal" is selected.</p>
	<p>Press <b>ENTER</b> to start the Auto Calibration configuration.</p>

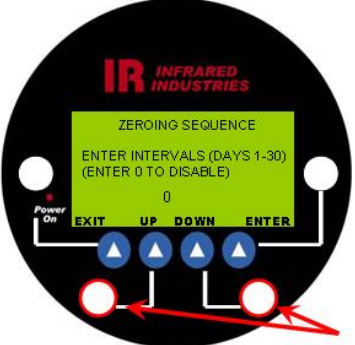
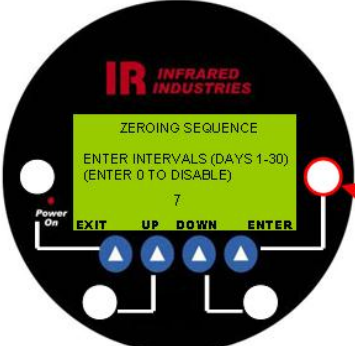
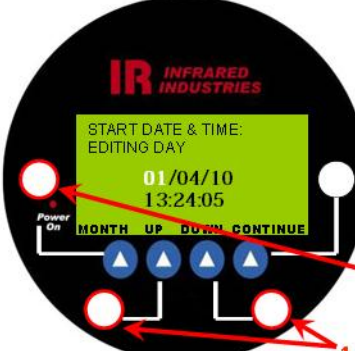
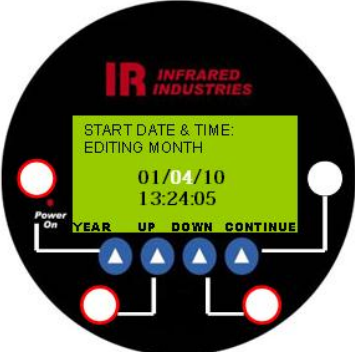
	<p>Using the <b>UP</b> and <b>DOWN</b> buttons you will set the frequency (in days) for the auto zeroing feature to run. This must be a value between 1 and 30.</p>
	<p>Once you have set the interval press <b>CONTINUE</b>.</p>
	<p>Set the start date and time for the first auto-zero. The date is displayed as day/month/year. Use the <b>UP</b> and <b>DOWN</b> buttons to select the day. When the day is selected press <b>MONTH</b> to select the month.</p>
	<p>Select the month by pressing the <b>UP</b> and <b>DOWN</b> buttons. When done select <b>YEAR</b> to edit the year.</p>

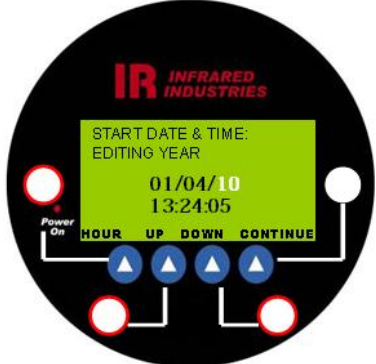
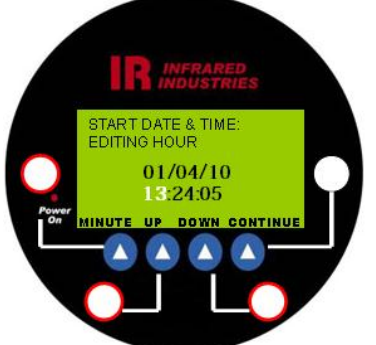
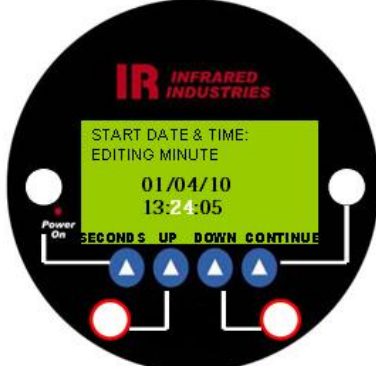
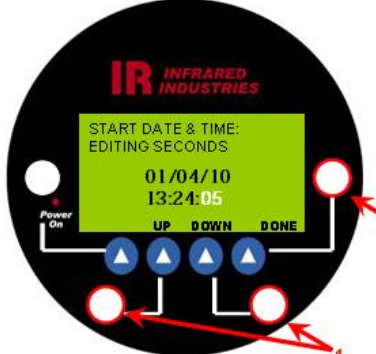
	<p>Select the year by pressing the UP and <b>DOWN</b> buttons. When done select <b>HOUR</b> to set the hour.</p>
	<p>The time is displayed in a twenty-four hour clock as hh:mm:ss. Select the hour by pressing the <b>UP</b> and <b>DOWN</b> buttons. When done select <b>MINUTE</b> to set the minutes.</p>
	<p>Select the minute by pressing the up and down buttons. When done select "Seconds" to set the seconds.</p>
	<p>Select the seconds by pressing the <b>up</b> and <b>down</b> buttons. When done select "<b>Continue</b>" to continue.</p>



Using the **UP** and **DOWN** buttons you will set the frequency (in days) for the auto calibrating feature to run. This must be a value between 1 and 30. It must be a multiple of the number of days between auto-zeroing. The calibration will immediately follow the auto-zero. A value of zero will disable auto-calibration. Select **Done** when complete.



# IR Sample Conditioner

## IR 1150 / 1151 SAMPLE CONDITIONER

The IR-1150/1151 sample conditioner provides a clean, dry sample to the analyzer at a constant flow rate, for sample pressures greater than 15 psig. The sample conditioner consists of:

- a) A particulate filter and liquids trap with input valve and auto-drain.
- b) A pressure regulator with safety relief valve.
- c) A second particulate filter and liquids trap with manual drain.
- d) A gas selector valve for zero, span and sample gases.
- e) A flow indicator with valve for adjusting the sample flow.
- f) All stainless steel construction.

The plate, on which the sample conditioner components are mounted, provides space and mounting hardware for installing the IR-8400D. Refer to figure 4: IR-1150/1151 Sample Conditioner.

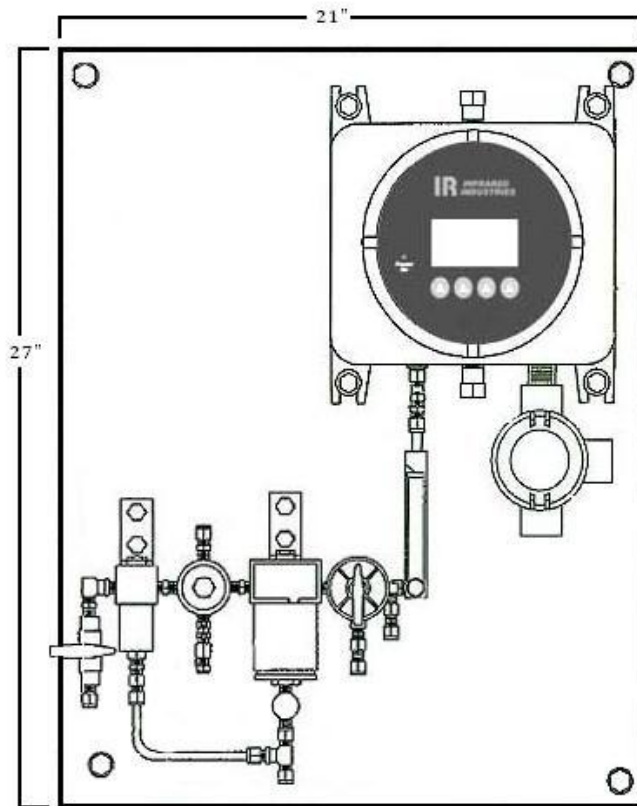

**Figure 4:** Panel mounted IR8400D and IR1151

The sample-in and sample-out connections are made through 3/8-inch compression tube fittings, while the span and zero gas inputs are made at the selector valve through 1/4-inch compression tube fittings. To install tubing to these fittings, cut the tubing square, and deburr as necessary. Insert the tubing into the fitting cap (cap in place) as far as it will go. Use one open-end wrench to hold the body of the fitting, and another to rotate the cap 1 1/4 turns past finger-tight. DO NOT OVER TIGHTEN. When reinstalling the tubing, rotate the cap no more than 1/8 turn past finger-tight.

In operation, the sample conditioner is designed to remove particulates and condensed vapors from the sample gas. The pressure regulator reduces the sample pressure to approximately 8 psig while the pressure relief valve limits the pressure to the flow meter to approximately 15 psig in case of regulator failure. The flow meter monitors and is used to adjust the flow of gas to the analyzer to approximately 1 scfh.

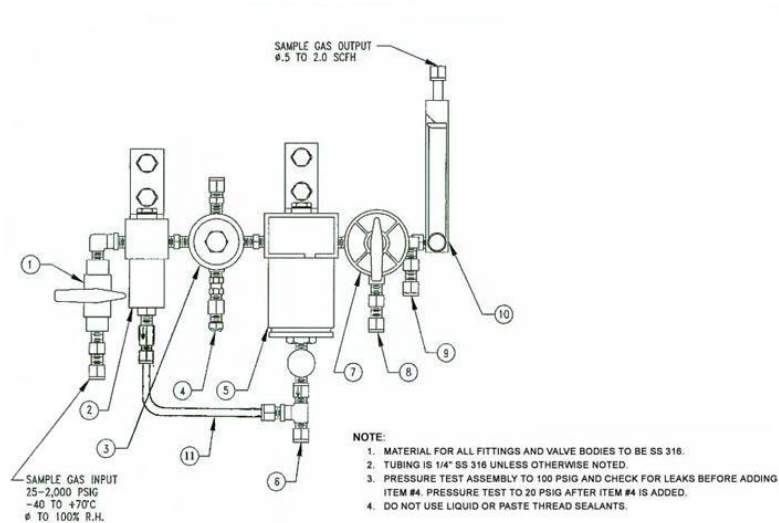

**Figure 5: IR1150/1151 Sample Conditioner**

- 1) Input Gas Shut-Off Valve
- 2) High-Pressure Filter with Constant Drain Port
- 3) Pressure Regulator (5-15 PSI, set @ 10 PSI)
- 4) Pressure Relief Valve (set @ 20 PSI)
- 5) Low Pressure Filter
- 6) Water Drain
- 7) 4-Way Sample/Cal/Zero Valve
- 8) Zero Gas Input (5-10 PSI, set @ 10 PSIG)
- 9) Cal Gas Input (5-10 PSI, set @ 10 PSIG)
- 10) Flow Regulator (0-5.0 SCFH, set @ 2 SCFH)
- 11) 3/8" SS Tubing (316)

## INSTALLATION

Mount the analyzer to the conditioner, using the SS hardware attached to the mounting plate. Mount the conditioner and analyzer to a firm, flat, vertical surface, protected from direct radiation by the sun. Use a sun shield, if necessary. Attach the tubing from the flow meter to the analyzer inlet, and tighten the compression fitting 1/8 turn past finger-tight. Install the zero and span gas lines to the selector valve at the appropriate fittings. Attach the bypass, drain, and sample-out gas lines and route to an area away from the analyzer.

***Note:** Both the zero and span gases should have regulators set for approximately 8 psig. With the sample inlet valve closed, attach the sample line to the sample inlet valve attached to the small filter holder.*

## INITIAL SETUP

Slowly open the sample inlet valve. With the selector valve in the SAMPLE position, as the flow increases, adjust the valve on the flow meter as necessary to maintain an indicated flow of 1 scfh. Rotate the gas selector valve to the ZERO position and adjust the pressure regulator on the zero gas bottle for an indicated flow of 1 scfh. Rotate the gas selector valve to the SPAN position, and adjust the pressure regulator on the span gas bottle for an indicated flow of 1 scfh. Return the selector valve to the **ZERO** or OFF position. The system is now ready to operate.

## OPERATION

Follow the CALIBRATION AND OPERATION instructions provided earlier in this manual. Use the gas selector valve to select the various gases. Open the drain valve located below the larger filter holder (if supplied) when liquid accumulates in the bowl.

## FILTER REPLACEMENT

If the flow to the analyzer drops significantly, indicating a clogged particulate filter, both the filter elements need to be replaced. To replace the element in the smaller filter holder, first turn off the sample inlet valve and remove the compression tube fitting attached at the bottom of the filter holder to free the filter bowl. Rotate the filter bowl clockwise (as viewed from the top) and remove the filter bowl and element. Check the condition of the automatic drain orifice, and clean if necessary, using .010 to .012 inch wire. Replace the filter element with a new one (Infrared Industries part no. 273-947) and reinstall the filter bowl in the reverse order as above.

**CAUTION: THE GASES AND LIQUIDS IN CONTACT WITH THE FILTER ELEMENTS MAY BE CORROSIVE AND TOXIC. CARE SHOULD BE TAKEN WHILE HANDLING THE ELEMENTS OR WHEN VENTING OFF THE RESIDUAL GAS LEFT IN THE FILTER HOLDERS.**

To replace the larger filter element, remove the compression fitting attached at the bottom of the filter holder to free the filter bowl. Remove the nut attached to the bottom and remove the filter bowl and element. If supplied, clean the automatic drain orifice as above. Replace the filter element with a new one (Infrared Industries part no. 273-943) and reinstall the filter bowl in the reverse order as above.

**Notice to Buyer and/or user of the analyzer:  
Exclusion of warranties and limitation of damages and remedies**

## **WARRANTY FOR ANALYZERS AND ACCESSORIES**

This analyzer is warranted against defects in materials and workmanship under normal use and service for one year from the date of delivery to the original purchaser.

The sole obligation of the seller and/or manufacturer under this warranty is limited to repairing or replacing as the seller or manufacturer may elect, free of charge at the place of business of the seller or manufacturer, any parts that prove, in the seller or manufacturers judgment, to be defective in materials or workmanship within one year after delivery to the original purchaser.

This warranty shall not apply and is void if, in the opinion of the seller and/or manufacturer, the portable analyzer or any component thereof has been damaged by accident, other causes not arising out of defects in materials or workmanship.

Before purchasing and using this analyzer, the user should determine the suitability of the product for his or her intended use and, the user assumes all risks and liabilities whatsoever in connection therewith.

## **WARRANTY EXCLUSIONS**

THIS WARRANTY AND THE SELLER AND/OR MANUFACTURER'S OBLIGATION HEREUNDER IS IN LIEU OF ALL OTHER WARRANTIES, EXPRESSED OR IMPLIED, INCLUDING WITHOUT LIMITATION, THE WARRANTIES OF MERCHANTABILITY AND FITNESS FOR A PARTICULAR PURPOSE, AND ALL OTHER REPRESENTATIONS CONCERNING THE SALE, USE AND/OR PERFORMANCE OF THE ANALYZER.

No person is authorized to give any other warranties or to assume any other liability on behalf of the seller or manufacturer. This warranty shall not be extended, altered or varied except by written agreement signed by the seller and the buyer.

## **LIMITATION OF DAMAGES**

IN NO EVENT SHALL THE MANUFACTURER OR SELLER OF THE PORTABLE ANALYZER BE LIABLE FOR ANY INCIDENTAL OR CONSEQUENTIAL DAMAGES ARISING OUT OF OR IN CONNECTION WITH ANY OBLIGATION IMPOSED UPON THE SELLER OR MANUFACTURER IN CONNECTION WITH THIS WARRANTY. SUCH INCIDENTAL AND CONSEQUENTIAL DAMAGES SHALL INCLUDE, WITHOUT LIMITATION, LOSS OF USE, LOSS OF INCOME, LOSS OF PROFIT (INCLUDING LOSSES TO BUSINESS INTERRUPTION), LOSSES SUSTAINED AS

THE RESULT OF INJURY (INCLUDING DEATH) TO ANY PERSON, AND LOSS OF OR DAMAGE TO PROPERTY. THE LIABILITY OF THE SELLER AND/OR MANUFACTURER ON THIS WARRANTY IS LIMITED TO ACCEPTING RETURN OF THE PORTABLE ANALYZER, REFUNDING ANY AMOUNT PAID THEREON AND CANCELING ANY BALANCE STILL OWING ON THE EQUIPMENT. THIS REMEDY IS EXCLUSIVE-REPAIR OR REPLACEMENT PROCEDURE.

If a product malfunction should occur, you may contact the seller or the manufacturer at:

**Infrared Industries, Inc.**

**25590 Seaboard Lane**

**Hayward, Ca. 94545 – USA**

**Phone: 510-782-8100**

**Fax: 510-782-8101**

**USA only: 800-344-0321**

**E-mail: [service@infraredindustries.com](mailto:service@infraredindustries.com)**

If it is necessary to return the exhaust emissions analyzer, notify the analyzer seller in your area or Infrared Industries at the address above. Package the instrument carefully and securely. Contact Infrared Industries for an RMA number, which is your authorization to send the unit. Note it carefully on the address label. Then proceed to ship the complete instrument with freight prepaid to the above address. Please include a written description of any observations of the malfunction.

Repaired instruments shall remain subject to the one-year warranty period. However, all replacement parts and service are warranted, subject to the limitations stated above, for 90 days from the date of delivery of the repaired instrument to the original buyer.



# *Instrument Identification Sheet*

---

**SALES ORDER NUMBER:** \_\_\_\_\_

**MODEL NUMBER:** \_\_\_\_\_

**SERIAL NUMBER:** \_\_\_\_\_

**GAS:** \_\_\_\_\_

**FULL SCALE VALUE:** \_\_\_\_\_

**RECORDER OUTPUT:** \_\_\_\_\_

**SPECIAL DATA:** \_\_\_\_\_

\_\_\_\_\_

**ORIGINAL PURCHASER:** \_\_\_\_\_

\_\_\_\_\_

\_\_\_\_\_

\_\_\_\_\_

**DATE OF ORIGINAL SHIPMENT:** \_\_\_\_\_